

---

---

**Water and soil quality —  
Determination of the toxic effect  
of sediment and soil samples on  
growth, fertility and reproduction of  
*Caenorhabditis elegans* (Nematoda)**

*Qualité de l'eau et du sol — Détermination de l'effet toxique  
d'échantillons de sédiment et de sol sur la croissance, la fertilité et la  
reproduction de *Caenorhabditis elegans* (Nématodes)*





**COPYRIGHT PROTECTED DOCUMENT**

© ISO 2020

All rights reserved. Unless otherwise specified, or required in the context of its implementation, no part of this publication may be reproduced or utilized otherwise in any form or by any means, electronic or mechanical, including photocopying, or posting on the internet or an intranet, without prior written permission. Permission can be requested from either ISO at the address below or ISO's member body in the country of the requester.

ISO copyright office  
CP 401 • Ch. de Blandonnet 8  
CH-1214 Vernier, Geneva  
Phone: +41 22 749 01 11  
Fax: +41 22 749 09 47  
Email: [copyright@iso.org](mailto:copyright@iso.org)  
Website: [www.iso.org](http://www.iso.org)

Published in Switzerland

# Contents

	Page
Foreword .....	iv
Introduction .....	v
<b>1 Scope</b> .....	<b>1</b>
<b>2 Normative references</b> .....	<b>1</b>
<b>3 Terms and definitions</b> .....	<b>1</b>
<b>4 Principle</b> .....	<b>2</b>
<b>5 Reagents and media</b> .....	<b>3</b>
<b>6 Apparatus</b> .....	<b>5</b>
<b>7 Reference substance</b> .....	<b>6</b>
<b>8 Organisms</b> .....	<b>7</b>
8.1 Test organism .....	7
8.2 Food organism .....	7
<b>9 Stock- and pre-cultures</b> .....	<b>7</b>
9.1 Stock cultures .....	7
9.1.1 <i>Caenorhabditis elegans</i> .....	7
9.1.2 <i>Escherichia coli</i> .....	7
9.2 Pre-culture .....	8
<b>10 Procedure</b> .....	<b>8</b>
10.1 Preparation of food medium .....	8
10.2 Preparation of test material and controls .....	8
10.2.1 Soil .....	8
10.2.2 Sediment .....	9
10.2.3 Pore water, elutriate, extract .....	9
10.2.4 Solution of reference substance .....	9
10.3 Test .....	10
10.4 Nematode separation .....	10
10.5 Measurements and calculations .....	10
10.5.1 Recovery .....	10
10.5.2 Males .....	10
10.5.3 Growth and fertility .....	11
10.5.4 Reproduction .....	11
10.6 Timetable of the test .....	12
<b>11 Validity criteria</b> .....	<b>13</b>
<b>12 Expression of results</b> .....	<b>13</b>
<b>13 Test report</b> .....	<b>14</b>
<b>Annex A (informative) Determination of maximal water holding capacity (WHC<sub>max</sub>)</b> .....	<b>15</b>
<b>Annex B (informative) Figures and photos of adult worms <i>C. elegans</i></b> .....	<b>16</b>
<b>Annex C (informative) Micropipette method (10.3)</b> .....	<b>18</b>
<b>Annex D (informative) Performance data</b> .....	<b>19</b>
<b>Bibliography</b> .....	<b>22</b>

## Foreword

ISO (the International Organization for Standardization) is a worldwide federation of national standards bodies (ISO member bodies). The work of preparing International Standards is normally carried out through ISO technical committees. Each member body interested in a subject for which a technical committee has been established has the right to be represented on that committee. International organizations, governmental and non-governmental, in liaison with ISO, also take part in the work. ISO collaborates closely with the International Electrotechnical Commission (IEC) on all matters of electrotechnical standardization.

The procedures used to develop this document and those intended for its further maintenance are described in the ISO/IEC Directives, Part 1. In particular, the different approval criteria needed for the different types of ISO documents should be noted. This document was drafted in accordance with the editorial rules of the ISO/IEC Directives, Part 2 (see [www.iso.org/directives](http://www.iso.org/directives)).

Attention is drawn to the possibility that some of the elements of this document may be the subject of patent rights. ISO shall not be held responsible for identifying any or all such patent rights. Details of any patent rights identified during the development of the document will be in the Introduction and/or on the ISO list of patent declarations received (see [www.iso.org/patents](http://www.iso.org/patents)).

Any trade name used in this document is information given for the convenience of users and does not constitute an endorsement.

For an explanation of the voluntary nature of standards, the meaning of ISO specific terms and expressions related to conformity assessment, as well as information about ISO's adherence to the World Trade Organization (WTO) principles in the Technical Barriers to Trade (TBT) see [www.iso.org/iso/foreword.html](http://www.iso.org/iso/foreword.html).

This document was prepared by Technical Committee ISO/TC 147, *Water quality*, Subcommittee SC 5, *Biological method*.

This second edition cancels and replaces the first edition (ISO 10872:2010), which has been technically revised. The main changes compared to the previous edition are as follows:

- the title has been changed to achieve a better perception in the field soil toxicity testing;
- for soil testing, the method has been modified in terms of a reduced water content of the test material;
- cited references and standards have been refreshed;
- information on the control soil and restrictions for tested soils has been added;
- the document has been editorially revised.

Any feedback or questions on this document should be directed to the user's national standards body. A complete listing of these bodies can be found at [www.iso.org/members.html](http://www.iso.org/members.html).

## Introduction

Nematodes are one of the most abundant and species-rich metazoans in sediments<sup>[1]</sup> and soils<sup>[2]</sup> and possess key positions in benthic and soil food webs due to the evolution of various feeding types (bacterial, algal, fungal and plant feeders, omnivores, predators see References [3] and [4]). Moreover, they are well acknowledged as environmental indicators for assessing the toxicity of chemicals and the quality of sediments and soils (see References [5], [6], [7], [8] and [9]).

The test organism *Caenorhabditis elegans* (Maupas, N2 var. Bristol) is a bacterivorous nematode that is found primarily in microbe-rich, decaying plant material (see Reference [10]) and belongs to the family of Rhabditidae, frequently found in terrestrial soils and aquatic sediments (see References [11] and [12]). Moreover, individuals of *C. elegans* were already found in sediments of polysaprobial fresh-water systems (see References [13] and [14]). Due to its easy cultivation and short life cycle<sup>[15]</sup>, *C. elegans* has become a well-studied model organism in biomedical and ecotoxicological research (see References [16], [17] and [18]).

The test is designed for measurement of the response to dissolved and particle-bound substances<sup>[19]</sup>. It applies to the testing of sediments, soils, waste, pore water, elutriates and aqueous extracts (see e.g. References [20], [21], [22] and [23]).



# Water and soil quality — Determination of the toxic effect of sediment and soil samples on growth, fertility and reproduction of *Caenorhabditis elegans* (Nematoda)

**WARNING** — Persons using this document should be familiar with normal laboratory practice. This document does not purport to address all of the safety problems, if any, associated with its use. It is the responsibility of the user to establish appropriate safety and health practices.

**IMPORTANT** — It is absolutely essential that tests conducted according to this document be carried out by suitably trained staff.

## 1 Scope

This document specifies a method for determining the toxicity of environmental samples on growth, fertility and reproduction of *Caenorhabditis elegans*. The method applies to contaminated whole freshwater sediment (maximum salinity 5 g/l), soil and waste, as well as to pore water, elutriates and aqueous extracts that were obtained from contaminated sediment, soil and waste.

## 2 Normative references

The following documents are referred to in the text in such a way that some or all of their content constitutes requirements of this document. For dated references, only the edition cited applies. For undated references, the latest edition of the referenced document (including any amendments) applies.

ISO 5667-16, *Water quality — Sampling — Part 16: Guidance on biotesting of samples*

ISO 7027-2, *Water quality — Determination of turbidity — Part 2: Semi-quantitative methods for the assessment of transparency of waters*

## 3 Terms and definitions

For the purposes of this document, the following terms and definitions apply.

ISO and IEC maintain terminological databases for use in standardization at the following addresses:

- ISO Online browsing platform: available at <https://www.iso.org/obp>
- IEC Electropedia: available at <http://www.electropedia.org/>

### 3.1

#### **agar plate**

Petri dish filled with Nematode Growth Medium (NGM) agar

### 3.2

#### **aqueous control**

water that serves as negative control for tests in aqueous samples

### 3.3

#### **artificial control sediment**

defined artificial sediment

### 3.4

#### **bacterial stock culture**

stock culture of food bacteria

**3.5**  
**blank replicate**  
additional replicate that contains no test organism, but is treated in the same way as the other replicates of a sample

**3.6**  
**control**  
treatment that serves as negative control to which the effect in the respective test material is compared

**3.7**  
**control soil**  
defined standard soil

**3.8**  
**dauer larva**  
developmental stage adopted by *C. elegans* to endure periods of lack of food

Note 1 to entry: Dauer larvae continue normal development if food is supplied.

**3.9**  
**exposed test organisms**  
individuals of *C. elegans* that are introduced at the beginning of the test

**3.10**  
**food medium**  
defined aqueous bacterial suspension

**3.11**  
**J<sub>1</sub> stage**  
first of four juvenile stages (J<sub>1</sub> to J<sub>4</sub>) in the development of *C. elegans*

**3.12**  
**maximal water holding capacity**  
WHC<sub>max</sub>  
maximal amount of water a soil sample is able to take up and keep against gravity

**3.13**  
**overnight culture**  
defined culture of *Escherichia coli* in Lysogeny Broth (LB)-medium

**3.14**  
**starved plate**  
*agar plate* (3.1) with dauer larvae

**3.15**  
**test material**  
discrete portion of a contaminated environmental sample or solution of the reference substance

## 4 Principle

Juvenile organisms of the species *C. elegans* are exposed to the environmental sample over a period of 96 h. In the controls, the exposed test organisms are able to complete a whole life cycle within this period. Toxicity can be quantified by the intensity of the effect as percentage inhibition. A toxic effect of an environmental sample occurs if the inhibition of growth, fertility or reproduction of *C. elegans* in comparison to a control (aqueous control, control sediment or soil) exceeds a certain threshold value (e.g. as proposed in the following publications: aqueous medium: 10 %, 20 %, 10 % inhibition, respectively (see Reference [24]); freshwater sediments: 25 %, 20 %, 50 % inhibition, respectively (see Reference [21]); soil: 10 %, 20 %, 40 % inhibition, respectively (see Reference [20]), and the performance of toxicity endpoints in the test material is statistically significantly lower compared to the control performance ( $p < 0,05$ ).



## 5 Reagents and media

Use only reagents of recognized analytical grade.

**5.1 Water**, distilled or deionized water or water of equivalent purity, conductivity  $\leq 10 \mu\text{S}/\text{cm}$ .

### 5.2 LB-medium

Dissolve

- 0,5 g of casein peptone;
- 0,25 g of yeast extract;
- 0,5 g of sodium chloride (NaCl);

in 50 ml water in a 250 ml flask and autoclave for 20 min at 121 °C.

### 5.3 Cholesterol stock solution

Dissolve 500 mg of powdered cholesterol in 100 ml of absolute ethanol (>99 % purity) by stirring and gentle heating (<50 °C). Replace ethanol lost through evaporation with ethanol.

**5.4 Calcium chloride stock solution**, 1 mol/l  $\text{CaCl}_2$ .

Dissolve 7,35 g of  $\text{CaCl}_2 \cdot 2\text{H}_2\text{O}$  in 50 ml water and autoclave for 20 min at 121 °C.

**5.5 Magnesium sulfate stock solution**, 1 mol/l  $\text{MgSO}_4$ .

Dissolve 12,35 g of  $\text{MgSO}_4 \cdot 7\text{H}_2\text{O}$  in 50 ml water and autoclave for 20 min at 121 °C.

**5.6 Potassium hydroxide**, KOH, pellets.

**5.7 Potassium phosphate buffer**, 1 mol/l  $\text{KH}_2\text{PO}_4$ .

Dissolve 13,6 g of  $\text{KH}_2\text{PO}_4$  in 100 ml of water, adjust with KOH (5.6) to pH  $6,0 \pm 0,2$ , and autoclave for 20 min at 121 °C.

### 5.8 Nematode growth-medium agar (NGM agar)

Dissolve

- 2,5 g of casein peptone;
- 17 g of bacteriological agar;
- 3 g of NaCl;

in 900 ml water in a 1 000 ml flask and autoclave for 20 min at 121 °C. After cooling down to 55 °C, add the following sterile solutions:

- 1 ml of cholesterol stock solution (see 5.3);
- 1 ml of calcium chloride stock solution (see 5.4);
- 1 ml of magnesium sulfate stock solution (see 5.5);
- 25 ml of potassium phosphate buffer (see 5.7);

and fill up to 1 000 ml with sterile water.

Transfer portions of NGM agar (about 20 ml to 25 ml) to sterile Petri dishes.

### 5.9 M9-medium

Dissolve

- 6 g of Na<sub>2</sub>HPO<sub>4</sub>;
- 3 g of KH<sub>2</sub>PO<sub>4</sub>;
- 5 g of NaCl;
- 0,25 g of MgSO<sub>4</sub>·7H<sub>2</sub>O;

in 1 000 ml of water in a 1 000 ml flask.

### 5.10 Bengal Rose stock solution

Add approximately 30 mg of Bengal Rose to 100 ml of water and stir thoroughly.

### 5.11 Ludox suspension

Dilute Ludox TM 50<sup>1)</sup> (colloidal silica; density: 1,4 g/cm<sup>3</sup>) with water to a density of (1,13 ± 0,005) g/cm<sup>3</sup> [mix approximately 1 part Ludox TM 50<sup>1)</sup> with 2 parts of water and control the density by weighing 1 ml of the suspension on a balance; 1 ml of the suspension weighs (1,13 ± 0,005) g]. For one 12 or 24-well multidish, approximately 75 ml or 150 ml of Ludox-suspension are required, respectively.

### 5.12 Artificial control sediment

Mix the following components thoroughly in the given proportions:

- Al<sub>2</sub>O<sub>3</sub>, 20 % mass fraction;
- CaCO<sub>3</sub>, 1 % mass fraction;
- dolomite (clay), 0,5 % mass fraction;
- Fe<sub>2</sub>O<sub>3</sub>, 4,5 % mass fraction;
- silica sand (for example: W4, mean particle size: 0,063 mm), 30 % mass fraction;
- silica sand (0,1 mm to 0,4 mm), 40 % mass fraction;
- peat (decomposed peat from a raised bog, untreated; finely ground and <1 mm sieved), 4 % mass fraction.

The dry sediment is maintainable without restraint.

This sediment serves as negative control for tests with sediments.

**WARNING — Artificial sediments with a kaolin content of >5 % mass fraction (e.g. OECD 218) can cause deleterious effects on growth, fertility and reproduction of *C. elegans*. If using a different artificial control sediment than proposed in this standard, the kaolin content shall be ≤5 % mass fraction.**

**WARNING — If available, the use of a site-specific reference sediment is advised, additionally to the artificial control sediment; the reference sediment shall match following criteria: limit of contamination; important sediment properties shall be similar to the tested sample (e.g. particle size distribution, organic content).**

1) Ludox™ 50 is an example of a suitable product available commercially. This information is given for the convenience of users of this document and does not constitute an endorsement by ISO of this product.

### 5.13 Control soil

Standard soil St. 2.2 from LUFA:

- soil type: loamy sand;
- organic carbon:  $(2,0 \pm 0,5)$  % mass fraction;
- pH ( $\text{CaCl}_2$ ):  $5,5 \pm 0,5$ ;
- cation exchange capacity:  $(10,0 \pm 0,4)$   $\text{mmol}_c/100$  g;  
NOTE  $\text{mmol}_c/100$  g is synonymous with  $\text{meq}/100$  g.
- water holding capacity:  $(48,2 \pm 5)$  %;
- clay content:  $(7,5 \pm 2,5)$  % mass fraction particles  $<0,002$  mm;
- silt content:  $(12,5 \pm 2,5)$  % mass fraction particles 0,002 mm to 0,063 mm;
- sand content:  $(80,0 \pm 5,0)$  % mass fraction particles 0,063 mm to 2 mm.

This soil serves as negative control for tests with soil.

NOTE LUFA refers to Landwirtschaftliche Untersuchungs- und Forschungsanstalt Speyer.

**WARNING — If tested soils contain >30 % clay even in uncontaminated soils, inhibiting effects on *C. elegans*' growth and reproduction might exceed the toxicity threshold. In these cases, a reference soil with a similar clay content shall be tested additionally to the control soil.**

**WARNING — Artificial soils with a kaolin content of >5 % mass fraction (e.g. OECD 207) can cause deleterious effects on growth, fertility and reproduction of *C. elegans*. If using a different artificial control soil than proposed in this standard, the kaolin content shall be  $\leq 5$  % mass fraction.**

### 5.14 Benzylcetyldimethylammonium chloride monohydrate (BAC-C16) stock solution

Dissolve 30 mg of BAC-C16 ( $\text{C}_{25}\text{H}_{46}\text{ClN}\cdot\text{H}_2\text{O}$ ; CAS No.: 122-18-9) in 1 000 ml of water.

### 5.15 Glycerol (>98 %; Ph.Eu., water free)

### 5.16 Formazin: Turbidity 4000 NTU calibration standard

## 6 Apparatus

### 6.1 Autoclave.

**6.2 Facilities**, with constant temperature for 20 °C and 37 °C, for example incubator or temperature-controlled chamber.

**6.3 Drigalski spatula**, glass spatula for distributing bacteria on an agar plate.

**6.4 Erlenmeyer flasks**, for example volume 250 ml.

**6.5 Plastic vials**, autoclavable and sealed, volume 1,5 ml.

**6.6 Filter gauze**, 5  $\mu\text{m}$ , 10  $\mu\text{m}$ .

6.7 **Freezer**, capable of maintaining temperature at  $-20\text{ }^{\circ}\text{C}$ .

6.8 **Micropipette** (see [Annex C](#)).

Draw a Pasteur pipette over a Bunsen burner to a thin capillary. Plug the Pasteur pipette in a suction cup at the thicker end.

6.9 **Microscope**, 100-fold magnification, with measurement scale.

6.10 **Thermometer**, minimum-maximum.

6.11 **Shaker**, for 250 ml Erlenmeyer flasks.

6.12 **Stereo microscope**, 4-fold to 20-fold magnification, with transmitted light.

6.13 **Clean bench**.

6.14 **Sterile Petri dishes**, of diameters 3 cm, 6 cm or 10 cm.

6.15 **Spectrophotometer**, capable of operating at wavelength 600 nm.

6.16 **Test tube mixer**.

6.17 **Balance**, 0,001 g readability.

6.18 **Drying oven**, approximately  $80\text{ }^{\circ}\text{C}$ .

6.19 **Multidishes**, with 12 wells,  $3,5\text{ cm}^2/\text{well}$  (sediment, water); with 24 wells,  $1,9\text{ cm}^2/\text{well}$  (soil).

6.20 **Centrifuge tubes**, 10 ml to 15 ml.

6.21 **Centrifuge with swing-out rotor**.

6.22 **Piston pipettes**, 10 ml to 100 ml, 100 ml to 1 000 ml.

6.23 **Sieves**, 1 mm and 2 mm.

6.24 **Magnetic stirrer and magnetic stirring bar**.

6.25 **pH-meter**.

6.26 **Inoculating loop**.

## 7 Reference substance

To ensure that the laboratory test conditions (including the condition and sensitivity of the exposed test organisms) are adequate and have not changed significantly, the laboratory shall test a reference substance as a positive control in parallel with each test, using one concentration near the  $\text{EC}_{50}$  for growth. The test parameters “fertility” and “reproduction” are not analysed when testing the reference substance. Use benzylcetyldimethylammonium chloride monohydrate (BAC-C16; [5.14](#)), which has been shown to affect growth of *C. elegans*, as reference substance. The positive control is tested in water according to the instructions for testing aqueous substrates ([10.1](#), [10.2.2](#), [10.3](#)). The inhibition of

growth at a concentration of 15 mg/l (EC<sub>50</sub> for BAC-C16, [5.14](#)) compared to the control should be in the range of 20 % to 80 %.

Additionally, the EC<sub>50</sub> of the reference substance shall be determined at least every 12 months. The EC<sub>50</sub> (growth) in water shall be in the range of 8 mg to 22 mg BAC/l using an EC<sub>x</sub> design as specified in ISO 5667-16. Stock solutions of BAC in the concentrations of 7,1 mg/l, 10,6 mg/l, 16 mg/l, 24 mg/l, 36 mg/l, 54 mg/l and 81 mg/l are prepared in water and tested according to the instructions for testing aqueous substrates (see [10.1](#), [10.2.2](#), [10.3](#)).

## 8 Organisms<sup>2)</sup>

### 8.1 Test organism

*Caenorhabditis elegans* (Maupas, 1899) is a widespread, free-living soil nematode that feeds primarily on bacteria. Adult worms are about 1,0 mm to 1,5 mm in length and can be distinguished into hermaphrodites and rarely occurring males (see [Annex B](#)). Hermaphrodites usually reproduce by self-fertilization although they can also be fertilized by males. After hatching, *C. elegans* develops to the adult stage through four juvenile stages separated by moults. Under starvation conditions, a developmentally arrested stage, the dauer larva, can be formed as an alternative third larval stage. The life cycle for worms grown on *E. coli* is about 3 d at 20 °C. The biology of *C. elegans* has been extensively studied and, in many respects, it is the most thoroughly characterized animal. The “wild type” strain N2 is used as test organism.

### 8.2 Food organism

As food organism for *C. elegans*, the bacterium *E. coli* (OP50; uracil-deficient strain) is used.

## 9 Stock- and pre-cultures

### 9.1 Stock cultures

#### 9.1.1 *Caenorhabditis elegans*

*C. elegans* is maintained on agar plates ([3.1](#)) with a bacterial lawn (*E. coli* OP 50; [8.2](#)) at (20 ± 2) °C. When bacteria are used up, *C. elegans* forms dauer larvae ([3.8](#)) due to lack of food. These starved plates ([3.14](#)) serve as stock cultures for *C. elegans* that should be replenished every two months. If too many males occur (≥10 % in tests), new stock cultures should be ordered.

#### 9.1.2 *Escherichia coli*

Inoculate under sterile conditions 50 ml of LB-medium ([5.2](#)) in a 250 ml Erlenmeyer flask ([6.4](#)) with *E. coli* from a bacterial lawn on agar [as sent by the supplier] using an inoculating loop ([6.25](#)) and incubate for 17 h at (37 ± 2) °C on a shaker ([6.11](#)) (overnight culture). Transfer 200 µl glycerol ([5.15](#)) into each 1,5 ml plastic vial ([6.5](#)) and sterilize in an autoclave ([6.1](#)) at 121 °C for 20 min. Add under sterile conditions 800 µl of the *E. coli* overnight culture ([3.13](#)), vortex and freeze immediately at -20 °C. Bacterial stock cultures are thawed only once and discarded after use. Bacterial stock cultures should be replenished after six months.

2) *Caenorhabditis elegans* and *Escherichia coli* can for example be supplied by: Caenorhabditis Genetic Center, Theresa Stiernagle, University of Minnesota, 6-160 Jackson Hall, 321 Church Street S.E., Minneapolis, MN 55455, E-mail: cgc@umn.edu, <http://www.cbs.umn.edu/CGC/>. This information is given for the convenience of users of this document and does not constitute an endorsement by ISO of these products.

## 9.2 Pre-culture

Inoculate under sterile conditions an agar plate (3.1) with approximately 200 µl of an overnight culture (3.13) of *E. coli*, distribute equally using a Drigalski spatula (6.3) and incubate for at least 8 h at  $(37 \pm 2)$  °C. Cut two or three small pieces (approximately 1 cm<sup>2</sup>) out of a starved plate (3.14) and transfer them under sterile conditions to an agar plate with a fresh lawn of *E. coli*. After about 3 d at 20 °C, a lot of gravid hermaphrodites as well as juveniles of stages 1 and 2 are found on the plate. The test starts with worms in the first juvenile stage (approx. 250 µm to 350 µm length). In order to obtain worms synchronized to this life stage, rinse the plate with M9-medium (5.9). Then filter the suspension containing the nematodes through a cascade of filter gauze (6.6) of 5 µm and 10 µm mesh size to retain larger juveniles and adults. The filtered suspension contains only first-stage juveniles (J<sub>1</sub>). Measure the length of 30 J<sub>1</sub> to obtain the initial length of the introduced exposed test organisms (mean value). For measuring the length of the J<sub>1</sub>, the organisms should be killed, e.g. by putting a sufficient number of J<sub>1</sub> in a drop of water placed on a microscopic slide and holding the slide for a few seconds over a flame.

## 10 Procedure

### 10.1 Preparation of food medium

After thawing, vortex (6.16) a vial with the *E. coli* stock vigorously. Inoculate under sterile conditions *x* times 50 ml of LB-medium (5.2) (depending on the demand) in 250 ml Erlenmeyer flasks (6.4) with approximately 20 µl of the *E. coli* stock each and incubate for 17 h at  $(37 \pm 2)$  °C on a shaker (6.11). To control the bacterial density after incubation, dilute an aliquot of the bacterial suspension 1→10 with LB-medium and measure the optical density at 600 nm against the LB-medium. The turbidity of the bacterial suspension shall be carried out in accordance with ISO 7027-2 in FAU (formazine absorption units; see 5.16). OD<sub>600</sub> is usually >200 FAU. After centrifugation of the bacterial suspension (20 min, 2 000 *g*), remove the supernatant and resuspend the pellet in M9-medium (5.9). After repeated centrifugation and removing of the supernatant, resuspend the pellet in approximately

- *x* times 1,6 ml of M9-medium and adjust the bacterial density to  $(60\ 000 \pm 3\ 000)$  FAU for testing soil;
- *x* times 8 ml of M9-medium and adjust the bacterial density to  $(12\ 000 \pm 600)$  FAU for testing sediment;
- *x* times 100 ml of M9-medium and adjust the bacterial density to  $(1\ 000 \pm 50)$  FAU for testing pore water, elutriates, extracts or solutions of reference substance.

Finally, the accurate volume of cholesterol stock solution is added (0,2 % of volume of bacterial suspension; for example, 100 µl of cholesterol stock solution in 50 ml bacterial suspension for testing sediment and liquid test material; 1 % of volume of bacterial suspension; for example 100 µl of cholesterol stock solution in 10 ml bacterial suspension for testing soil).

NOTE Densities of bacteria differ between tests with soil, sediment and liquid test material due to different exposure conditions.

### 10.2 Preparation of test material and controls

#### 10.2.1 Soil

Pass the test material (3.15) through a 2 mm sieve (6.23). Determine the dry mass of the test material and control soil in accordance with ISO 11465<sup>[25]</sup> by drying a small portion of the test sample. Determine the pH and electrical conductivity of the test material and control soil in accordance with ISO 10390<sup>[26]</sup> and ISO 11265<sup>[27]</sup>. Determine clay content (% particles <2 µm) in accordance with ISO 14688-1:2017<sup>[28]</sup>. Determine the maximal water holding capacity of test and control soils (WHC<sub>max</sub>; Annex A).

Prepare at least four replicates for each test material and the control soil (5.13). Prepare one additional blank replicate (without test organisms) to estimate the number of indigenous nematodes in the samples. Dry an appropriate amount of soil at room temperature. Transfer  $(0,500 \pm 0,010)$  g (dry mass)

of test material into each test well (6.19), add  $l$  ml M9-medium (5.9) to adjust soil moisture to 80 % of  $WHC_{max}$  and stir with a spatula to achieve homogenous material. Calculate  $l$ , expressed in ml, as given in Formula (1):

$$l = 0,5 \times (0,8 \times WHC_{max}) - 0,1 \text{ ml} \quad (1)$$

Store in a refrigerator at  $(4 \pm 3)$  °C to avoid loss of moisture.

Stir the food medium (10.1) to ensure homogeneity and add, immediately before the start of the test, 0,1 ml of homogenized food medium (10.1) to each test well. Mix control soil and test material with the added food medium thoroughly with a spatula.

### 10.2.2 Sediment

Pass the test material (3.15) through a 2 mm sieve (6.23). Determine the dry mass of the test material and control sediment in accordance with ISO 11465<sup>[25]</sup> by drying a small portion of the test sample. Determine the pH and electric conductivity of the test material and control sediment in accordance with ISO 10390<sup>[26]</sup> and ISO 11265<sup>[27]</sup>.

Prepare at least four replicates for each test material and the control [artificial control sediment (5.12) and reference sediment, if applicable]. Prepare one additional blank replicate (without test organisms) to estimate the number of indigenous nematodes in the samples. For artificial substrates, such as the artificial control sediment, it is not necessary to set up a blank replicate. For test material with  $\geq 40$  % water content (based on total mass), transfer  $(0,500 \pm 0,010)$  g (wet mass) of test material into each test well (6.19). For test material with  $< 40$  % water content (based on total mass), artificial control sediment, transfer  $m \pm 0,010$  g into each test well, add  $(0,500 - m)$  ml of M9-medium (5.9), and stir with a spatula to achieve a homogenous suspension. Calculate  $m$ , expressed in grams, as given in Formula (2):

$$m = \frac{0,5 \times 0,60}{m_{o,t}} \quad (2)$$

where  $m_{o,t}$  is the measured dry mass of the test material.

Store in a refrigerator at  $(4 \pm 3)$  °C to avoid loss of moisture.

Stir the food medium (10.1) to ensure homogeneity and add, immediately before the start of the test, 0,5 ml of homogenized food medium (10.1) to each test well. Mix artificial control sediment and test material with the added food medium thoroughly with a spatula.

### 10.2.3 Pore water, elutriate, extract

Determine the pH and electric conductivity of the test material and control sediment in accordance with ISO 10523<sup>[29]</sup> and ISO 7888<sup>[30]</sup>.

Prepare at least four replicates for each test material (3.15) and the control (aqueous control (3.2)). Transfer 0,5 ml of test material and aqueous control into each test well (6.19). Stir the food medium (10.1) to ensure homogeneity and add, immediately before the start of the test, 0,5 ml of homogenized food medium to each test well. Mix control and test material with the added food medium by gently shaking the wells.

### 10.2.4 Solution of reference substance

Prepare at least four replicates for each solution of the reference substance (5.14, see also Clause 7) and the control [aqueous control (3.2)]. Transfer 0,5 ml of the solution of reference substance and aqueous control into each test well (6.19). Stir the food medium (10.1) to ensure homogeneity and add, immediately before the start of the test, 0,5 ml of homogenized food medium to each test well. Mix control and solutions of reference substance with the added food medium by gently shaking the wells.

### 10.3 Test

At the start of the test, transfer ten first-stage juveniles ( $J_1$ ; test organisms) from the filtrate by micropipette (6.8, see Annex C) to each of the test wells containing test material (3.14) and food medium (10.1) (after allowing temperature to equilibrate to room temperature). Juveniles enter the micropipette by capillary force and are dispensed to the test wells by pressing the bulb (see also Figure C.1; density of  $J_1$  should not be too high, so that entrance of organism in the micropipette can still be counted in a controlled manner). Non-moving organisms should be excluded from the test. After the addition of the test organisms, seal the multidishes (6.19) with an adhesive tape [Parafilm<sup>3</sup>] and incubate at  $(20 \pm 1)^\circ\text{C}$  in the dark. After 96 h, add approximately 0,5 ml of Rose Bengal stock solution (5.10) to each test well to stain the nematode cuticle for better recovery. Heat the multidishes with the lid on in a drying oven for 10 min at  $80^\circ\text{C}$  to terminate the test. This treatment results in straightened, easily measurable worms. Until further processing, samples are stored at  $(4 \pm 3)^\circ\text{C}$ . Samples should be analysed within four weeks.

### 10.4 Nematode separation

Transfer the sediment, soil or waste of each test well (10.3) into a separate centrifuge tube (10 ml to 15 ml) using tap water and a Pasteur pipette. Centrifuge the samples using a swing-out rotor (6.21) for 5 min at  $800\text{ g}$  and decant aqueous supernatant with caution into a separate test tube (test tube #1; 10 ml to 15 ml) for further analysis. Add 2 ml of Ludox suspension (5.11) to the centrifuge tube containing the sediment, soil or waste pellet, mix thoroughly using a test tube mixer (6.16) and centrifuge the samples using a swing-out rotor for 5 min at  $800\text{ g}$ . The exposed test organisms and their offspring can be found in the Ludox supernatant that is decanted in a new separate test tube (test tube #2; 10 ml to 15 ml). The sediment or soil pellet, remaining in the centrifuge tube, is again thoroughly mixed with 2 ml Ludox suspension and centrifuged. Repeat the Ludox separation three times, so that test tube #2 contains 6 ml of Ludox containing the separated nematodes. The gathered Ludox suspension with separated nematodes is decanted into a Petri dish (6.14) for further analysis. Both organisms in the aqueous (test tube #1) and Ludox supernatant (test tube #2) (exposed test organisms and offspring) are considered for measurements and calculations (10.5).

In case of testing aqueous samples, no separation steps are necessary. Rinse the content of one test well in a Petri dish for further analysis using tap water and a Pasteur pipette.

### 10.5 Measurements and calculations

#### 10.5.1 Recovery

Count the separated exposed test organisms (3.9; 10.4) and calculate the percentage of recovered exposed test organisms by dividing the total number of recovered exposed test organisms (including male exposed test organisms) by the number of introduced test organisms, (10), and multiplying by 100. For an example, see Tables 1 and 2. For the blank replicate, count the total number of nematodes.

#### 10.5.2 Males

Males can occur at low frequencies. Count the males in the replicates and exclude them from further measurement of growth (10.5.3) and calculations of fertility (10.5.3) as adult males are generally smaller than adult hermaphrodites and males are not able to produce eggs. For the calculation of reproduction the number of males is required, as this value is subtracted from the number of introduced test organisms (10) by which the total offspring is divided (10.5.4). Determine the percentage of male exposed test organisms by dividing the number of males by the total number of recovered exposed test organisms and multiplying by 100. For an example, see Tables 1 and 2.

This subclause doesn't apply to the blank replicate.

---

3) Parafilm<sup>TM</sup> is an example of a suitable product available commercially. This information is given for the convenience of users of this document and does not constitute an endorsement by ISO of this product.



**10.5.3 Growth and fertility**

Transfer the separated exposed test organisms from the Petri dish to a microscopic slide using a stereo microscope (4-fold to 20-fold magnification; 6.12). Measure the body length of the exposed test organisms under a microscope (100-fold magnification) using a measurement scale (males are not measured) and determine if there are eggs inside the body of each exposed test organism. A worm is considered gravid if the number of eggs inside the body is  $\geq 1$ .

Calculate the mean body length for each replicate for further calculations.

Calculate the mean growth per replicate as the difference of the mean measured body length and mean body length of 30  $J_1$  at the beginning of the test (as determined in 9.2). For an example, see Tables 1 and 2.

Calculate per replicate the percentage of gravid exposed test organisms in relation to the total number of recovered hermaphroditic exposed test organisms (fertility) by dividing the number of gravid exposed test organisms by the total number of recovered exposed test organisms (less the number of males) and multiplying by 100. For an example, see Tables 1 and 2.

This subclause does not apply to the blank replicate.

**Table 1 — Example for the calculation of mean growth and fertility in six replicates of the control**

Exposed test organism	Replicates											
	1		2		3		4		5		6	
	$l_1 \mu\text{m}$	Gravid	$l_1 \mu\text{m}$	Gravid	$l_1 \mu\text{m}$	Gravid	$l_1 \mu\text{m}$	Gravid	$l_1 \mu\text{m}$	Gravid	$l_1 \mu\text{m}$	Gravid
1	1 430	+	1 450	+	1 400	+	1 380	+	1 480	+	1 470	+
2	1 480	+	1 500	+	1 450	+	1 430	+	1 530	+	1 520	+
3	1 350	+	1 370	+	1 320	+	1 300	+	1 400	+	1 390	+
4	1 520	+	1 540	+	1 490	+	1 470	+	1 570	+	1 560	+
5	1 410	+	1 430	+	1 380	+	1 360	+	1 460	+	1 450	+
6	1 430	+	1 450	+	1 400	+	1 380	+	1 480	+	1 470	+
7	1 450	+	1 470	+	1 420	+	1 400	+	900	-	1 490	+
8	1 390	+	1 410	+	1 360	+	1 340	+	1 440	+	1 430	+
9	male		n.r.		n.r.		1 410	+	male		1 500	+
10	n.r.		n.r.		n.r.		1 290	+	male		n.r.	
$\bar{l}_1 \mu\text{m}$	1 433		1 453		1 403		1 376		1 408		1 476	
$\bar{l}_{0,J_1} \mu\text{m}$	290		290		290		290		290		290	
<b>Mean growth, <math>\mu\text{m}</math></b>	1 143		1 163		1 113		1 086		1 118		1 186	
<b>Fertility, %</b>	100		100		100		100		87,5		100	
$\bar{l}_1$	mean body length of the measured exposed test organisms											
$\bar{l}_{0,J_1}$	mean initial body length of the introduced $J_1$ (as calculated for 30 $J_1$ ; in micrometres)											
+	gravid											
-	not gravid											
n.r.	not recovered											

**10.5.4 Reproduction**

Count the number of offspring (second-generation juveniles) by using a stereo microscope (4-fold to 20-fold magnification). Counting can be done directly under the microscope or from photographs taken with a camera mounted at the microscope. Divide this number by the number of introduced test

organisms (10) less the number of males. Express the results as offspring per exposed test organisms (reproduction; including the impact of mortality). For an example, see [Table 2](#).

[10.5.4](#) does not apply to the blank replicate.

NOTE Using a counting dish with grids delimiting fields of defined area, nematodes can be counted in a defined number of fields and extrapolated to the area of the whole counting dish.

**Table 2 — Example for calculation of test parameters and validity criteria in the control**

Parameter	Replicates						Mean
	1	2	3	4	5	6	
Number of introduced test organisms	10	10	10	10	10	10	
Number of recovered exposed test organisms	9	8	8	10	10	9	
Number of males	1	0	0	0	2	0	
Number of measured exposed test organisms	8	8	8	10	8	9	
Number of gravid exposed test organisms	8	8	8	10	7	9	
Number of offspring	675	550	650	450	480	550	
Recovery, %	90	80	80	100	100	90	90
Males, %	11,1	0	0	0	20	0	5
Mean growth, µm	1 143	1 163	1 113	1 086	1 118	1 186	1 135
Fertility, %	100	100	100	100	87,5	100	98
Reproduction	75	55	65	45	60	55	59

**10.6 Timetable of the test**

Day D-4	Preparation of agar plates with fresh bacterial lawn ( <a href="#">9.2</a> )	
Day D-3	Transferring of dauer larvae to agar plate with fresh bacterial lawn ( <a href="#">9.2</a> )	
Day D-2	Determination of dry mass/WHC <sub>max</sub> of test material and control ( <a href="#">10.2.1</a> )	
Day D-1	1	Weighing of test material and control in test wells ( <a href="#">10.2.1</a> )
	2	Adjustment of water content of test material and control ( <a href="#">10.2.1</a> )
	3	Inoculation of LB-medium with bacterial stock ( <a href="#">10.1</a> )
Day D	1	Preparation of food medium ( <a href="#">10.1</a> )
	2	Mixing of test medium and control with food medium ( <a href="#">10.2</a> )
	3	Synchronization of test organisms ( <a href="#">9.2</a> )
	4	Addition of test organisms to test wells and incubation at 20 °C in the dark ( <a href="#">10.3</a> )
	5	Determination of initial body length ( <a href="#">9.2</a> )
Day D+4	1	Addition of Rose Bengal ( <a href="#">10.3</a> )
	2	Termination of test (heat fixing; <a href="#">10.3</a> )
	3	Storage at (4 ± 3) °C till analysis ( <a href="#">10.3</a> )

SINGLE USER LICENSE ONLY. SUPPLIED BY BSB EDGE UNDER LICENCE FROM ISO FOR CSIR-INDIAN INSTITUTE OF TOXICOLOGY RESEARCH (IITR) - LUCKNOW VIDE BSB EDGE ORDER NO. EST04-2568 ON 25/03/2021

## 11 Validity criteria

The test is considered valid if

- the mean recovery of exposed test organisms (10.5.1) from the control is  $\geq 80\%$  and  $\leq 120\%$ ;
- the mean percentage of males (10.5.2) in the control is  $\leq 10\%$ ; the percentage of males in a single control replicate is  $\leq 20\%$  (for an example, see Tables 1 and 2);
- the mean fertility (10.5.3) in the control is  $\geq 80\%$ ;
- the mean reproduction (10.5.4) in the control is  $\geq 50$  offspring per test organism;
- coefficients of variance of the endpoints measured for the negative control shall not exceed 15 % for growth and fertility and 30 % for reproduction;
- The total number of nematodes in the blank replicate accounts for  $< 20\%$  of the mean total number of nematodes found in the replicates with *C. elegans*.

Recovery of exposed test organisms from the control sediment or control soil is an indicator of accuracy when adding test organisms (10.3) and accuracy of nematode separation (10.4). The determination of  $\geq 80\%$  and  $\leq 120\%$  recovery as validity criteria ensures a certain accuracy for the calculations of reproduction.

Males do not influence test results substantially if they occur in low frequencies ( $< 10\%$ ). Above a certain threshold (20 %; 2 of 10 exposed test organisms), calculation of test parameters can be biased. Moreover, mean percentages of males of  $> 10\%$  indicate cultures that are not appropriate for the requirements of this test. In this case, it is recommended that new cultures be ordered.

If the total number of nematodes in the blank replicate accounts for  $> 20\%$  of the mean total number of nematodes found in the replicates with *C. elegans*, the soil shall be defaunated.

## 12 Expression of results

For each treatment, calculate the mean and standard deviation from the replicate data. Moreover, express the results as inhibition of a test parameter,  $x_t$ , expressed as a percentage relative to the corresponding value in the control, as given in Formula (3):

$$x_t = 100 - \frac{\bar{x}_A}{\bar{x}_C} \times 100 \quad (3)$$

where

$\bar{x}_A$  is the mean of the parameter in sample A;

$\bar{x}_C$  is the mean of the parameter in the control.

**Table 3 — Example for calculation of the percentage inhibition of test parameters**

Parameter	Control	Sample A	Inhibition %
Growth, $\mu\text{m}$	1 135	700	38
Fertility, %	98	80	18
Reproduction (offspring per exposed test organism)	60	15	75

See Annex D for performance data.

### 13 Test report

The test report shall contain at least the following information:

- a) the test method used, together with a reference to this document, i.e. ISO 10872:2020;
- b) name of the laboratory performing the test;
- c) date and period of test;
- d) test organism (e.g. systematic name, strain, source);
- e) food organism (e.g. systematic name, strain, source);
- f) designation of test material (batch number, origin, date and period of sampling);
- g) sample pre-treatment and characteristics (storage period and conditions, water content, water holding capacity, pH and particle size distribution of sediment or soil);
- h) test conditions: bacterial density in FAU; minimal and maximal temperature during the test; initial body length of exposed test organisms (mean and standard deviation); number of indigenous nematodes in the blank replicate;
- i) results (mean and standard deviation of test parameters in treatments and control, percentage inhibition of test parameters in all treatments);
- j) details of test results (e.g. replicate data);
- k) results from the test with reference substance;
- l) any deviations from the test protocol.

## Annex A (informative)

### Determination of maximal water holding capacity ( $WHC_{max}$ )

The following method has been found to be appropriate for laboratory samples of test soils and standard soils.

#### A.1 Apparatus

**A.1.1 Glass tube**, approximately 20 mm to 50 mm diameter and at least 100 mm in length.

**A.1.2 Water bath**, at room temperature.

**A.1.3 Filter paper**.

**A.1.4 Drying oven**, set to  $(105 \pm 5)$  °C.

**A.1.5 Balance**, capable of weighing with an accuracy of  $\pm 0,1$  g.

#### A.2 Method

Plug the bottom of the tube with filter paper, and after filling it with soil to a depth of 5 cm to 7 cm, place the tube on a rack in a water bath. Gradually submerge the tube until the water level is above the top of the soil but below the upper edge of the tube. Leave the substrate sample in the water for about 3 h.

As not all water absorbed by the substrate capillary can be retained, the tube containing the sample should be placed for a period of 2 h on very wet finely ground quartz sand for draining. The same quartz sand as is used for the artificial control sediment (silica sand; 0,1 mm to 0,4 mm) substrate is satisfactory.

Weigh the sample, dry it to constant mass at 105 °C and reweigh it.

#### A.3 Calculation of $WHC_{max}$

$$WHC_{max} = \frac{m_S - m_T - m_D}{m_D} \times 100 \quad (A.1)$$

where

$WHC_{max}$  is the maximal water-holding capacity in percentage of dry mass, %;

$m_S$  is the mass of the water-saturated substrate plus the mass of the tube plus the mass of the filter paper;

$m_T$  is the tare (mass of tube plus mass of filter paper);

$m_D$  is the dry mass of substrate.

## Annex B (informative)

### Figures and photos of adult worms *C. elegans*

Explanation to [Figure B.1](#):

A. Differential interference contrast (DIC) image of an adult hermaphrodite, left lateral side. Scale bar 0,1 mm.

B. Schematic drawing of anatomical structures, left lateral side. Dotted lines and numbers mark the level of each section: 2B: Section through anterior head. 2C: Section through the middle of head, 2D: Section through posterior head. 2E: Section through posterior body. 2F: Section through tail, rectum area.

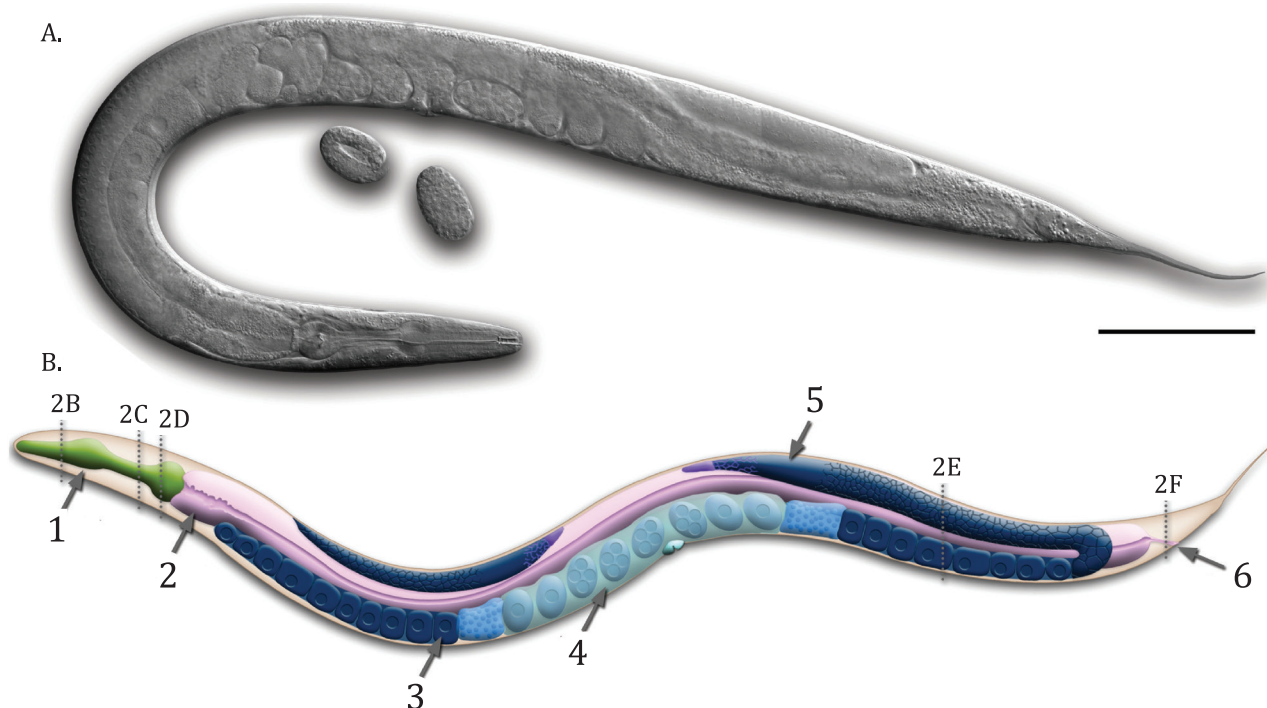

#### Key

- 1 pharynx
- 2 intestine
- 3 proximal gonad
- 4 uterus
- 5 distal gonad
- 6 anus

**Figure B.1 — *C. elegans* Adult hermaphrodite**

[SOURCE Altun, Z.F. and Hall, D.H. 2009. Introduction. In WormAtlas. [doi:10.3908/wormatlas.1.1](https://doi.org/10.3908/wormatlas.1.1)]

Explanation to [Figure B.2](#):

- A. Schematic drawing of anatomical structures, left lateral side.  
 B. Differential interference contrast (DIC) image of an adult male, left lateral side, scale bar 0,1 mm.

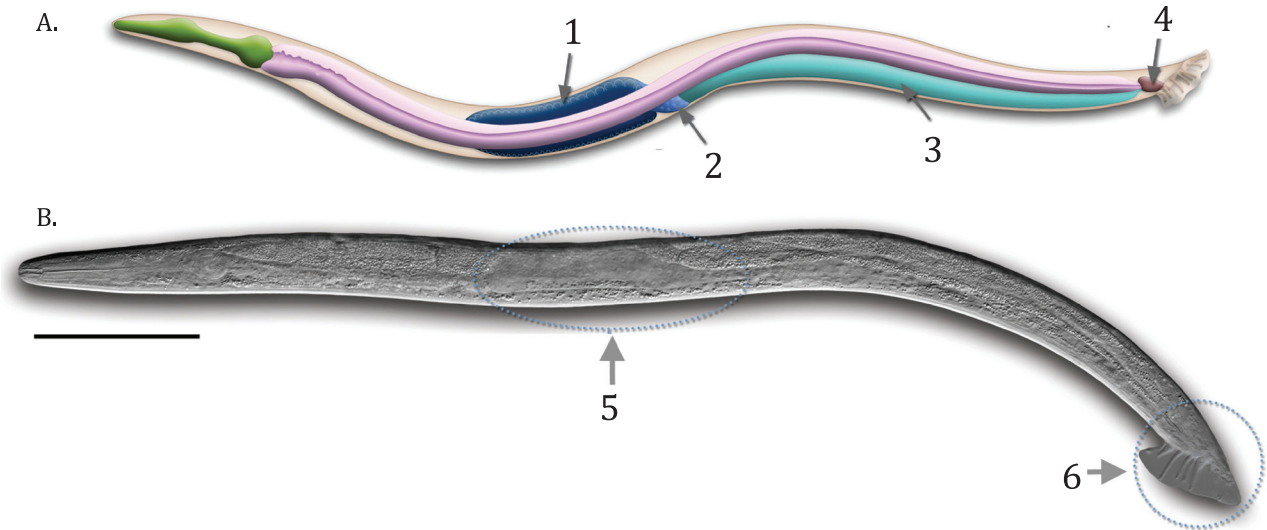

**Key**

- 1 gonad
- 2 seminal vesicle
- 3 vas deferens
- 4 proctodeum
- 5 unilobal distal gonad
- 6 tail region

**Figure B.2 — *C. elegans* male**

[SOURCE Altun, Z.F. and Hall, D.H. 2009. Introduction. In WormAtlas. [doi:10.3908/wormatlas.1.1](https://doi.org/10.3908/wormatlas.1.1)]

**Annex C**  
(informative)

**Micropipette method (10.3)**

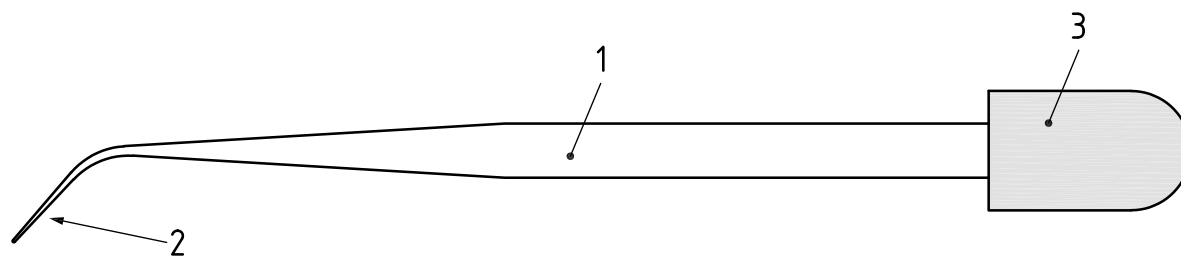

**a) Micropipette**

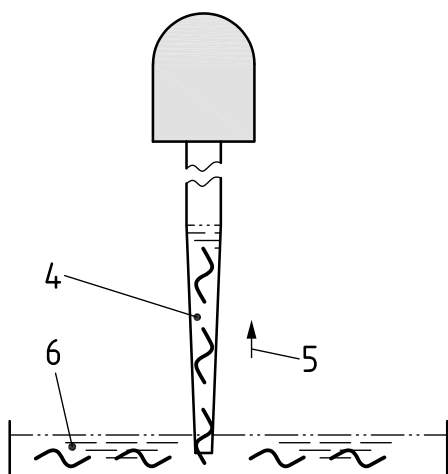

**b) Step 1: Pick up juvenile test organisms**

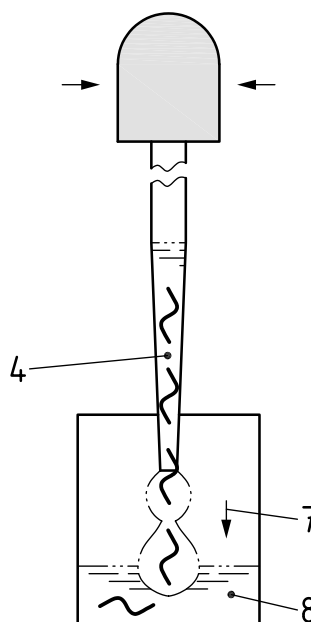

**c) Step 2: Dispense juvenile test organisms**

**Key**

- |   |                                  |   |                                |
|---|----------------------------------|---|--------------------------------|
| 1 | pasteur pipette                  | 5 | capillary force                |
| 2 | capillary, opening approx. 20 µm | 6 | test organisms, J <sub>1</sub> |
| 3 | suction cup                      | 7 | test well                      |
| 4 | capillary                        | 8 | test material and food medium  |

**Figure C.1 — Description of micropipette test method**



## Annex D (informative)

### Performance data

International interlaboratory tests based on the test described in this document were carried out in 2009 based on ISO/DIS 10872 of 2009 and in 2019 based on the revised ISO/DIS 10872:2019. The results with the reference substance BAC-16 for EC<sub>50</sub> for the parameter growth, as well as results with contaminated sediment and soil samples for the parameters growth and reproduction are shown in [Table D.1](#) (2019: only soil). Additionally, for the sediment and soil tests, all parameters required for determining the validity criteria ([Clause 11](#)) are summarized in [Table D.2](#) (2009) and [Table D.3](#) (2019). Note that performance data for tests contaminated soils in 2009 ([Table D.1](#)) refer to a method described in a former version of this standard (ISO 10872:2010) that has been revised. Moreover, all data in [Table D.2](#) refer to validity criteria described in a former version of this standard (ISO 10872:2010) that has been revised.

**Table D.1 — Interlaboratory test results — Toxicity parameters**

Interlaboratory Test 2009									
Substance/sample	Parameter	<i>l</i>	<i>n</i>	<i>o</i> %	$\bar{x}$ mg/l (EC <sub>50</sub> )	<i>s<sub>R</sub></i> mg/l (EC <sub>50</sub> )	<i>C<sub>V,R</sub></i> %	<i>s<sub>r</sub></i> mg/l (EC <sub>50</sub> )	<i>C<sub>V,r</sub></i> %
BAC-C16	EC <sub>50</sub> growth	8	18	0,0	15,1	1,68	11,1	1,14	7,6
Contaminated soil	% inhibition growth	8	16	0,0	23,8	7,97	33,5	3,87	16,3
	% inhibition reproduction	7	14	12,5	83,3	11,80	14,2	7,80	9,4
Contaminated sediment	% inhibition growth	8	16	0,0	18,1	4,95	27,4	2,41	13,3
	% inhibition reproduction	8	16	0,0	63,7	18,34	28,8	8,62	13,5
Interlaboratory Test 2019									
Sample	Parameter	<i>l</i>	<i>n</i>	<i>o</i> %	$\bar{x}$	<i>s<sub>R</sub></i>	<i>C<sub>V,R</sub></i> %	<i>s<sub>r</sub></i>	<i>C<sub>V,r</sub></i> %
Contaminated soil	% inhibition growth	9	17	5,6%	20,4	15,1	74,1	7,3	35,7
	% inhibition reproduction	9	18	0	70,9	20,8	29,3	8,5	12,0
<i>l</i> number of laboratories after elimination of outliers <i>n</i> number of valid measured values after elimination of outliers <i>o</i> percentage of outliers $\bar{x}$ overall mean <i>s<sub>R</sub></i> reproducibility standard deviation <i>C<sub>V,R</sub></i> coefficient of variation of reproducibility <i>s<sub>r</sub></i> repeatability standard deviation <i>C<sub>V,r</sub></i> coefficient of variation of repeatability									

**Table D.2 — Interlaboratory test results 2009 — Validity criteria for sediment and soil tests (valid tests)**

	Recovery		Males		Fertility		Reproduction (number of offspring per test organism)	
	%		%		%		Control sediment	Control soil
	Control sediment	Control soil	Control sediment	Control soil	Control sediment	Control soil		
Labor. 1/1	84	92	0	0	100	100	85	117
Labor. 1/2	92	86	0	0	100	100	153	165
Labor. 2/1	100	92	2	6	100	100	87	55
Labor. 2/2	100	98	0	0	100	100	110	66
Labor. 3/1	100	90	0	0	100	100	90	79
Labor. 3/2	98	100	0	0	100	100	80	93
Labor. 4/1	82	94	0	0	100	100	235	90
Labor. 4/2	100	92	0	0	100	100	109	149
Labor. 5/1	100	98	0	0	100	100	127	127
Labor. 5/2	100	96	0	0	100	100	121	135
Labor. 6/1	92	96	6	0	100	100	114	121
Labor. 6/2	84	96	4	8	100	100	102	130
Labor. 7/1	94	80	0	0	100	100	82	54
Labor. 7/2	80	96	0	0	100	100	71	75
Labor. 8/1	100	86	0	0	100	100	103	104
Labor. 8/2	100	96	0	0	100	100	80	106

**Table D.3 — Interlaboratory test results 2019 — Validity criteria for soil tests (valid tests; control soil)**

Lab ID/Test	Recovery	Males (mean/max)	Fertility	Reproduction	%CV Growth	%CV Fertility	% CV Reproduction
	%	%	%	Number of offspring per test organism	%	%	%
L01 Test1	88	0	100	186	1,8	0,0	19,2
L01 Test2	92	0	100	240	3,8	0,0	10,0
L01 Test 3	96	0	100	233	1,7	0,0	8,6
L01 Test 4	82	0	100	152	1,9	0,0	10,2
L01 Test 5	86	0	100	110	4,2	0,0	19,9
L02 Test1	88	0	100	96	4,2	0,0	16,3
L02 Test2	94	2,1/12,5	100	111	3,7	0,0	19,7
L02 Test3	94	0	100	104	3,6	0,0	11,5
L03 Test1	86	0	95,3	51	5,4	6,3	13,1
L04 Test2	91	2,6/11,1	100	60,7	4,1	0,0	5,8
L07 Test2	93,3	0	100	115	6,6	0,0	22,7
L07 Test3	88,3	0	100	151	2,0	0,0	16,0
L08 Test1	92	0	100	102	5,2	0,0	17,7
L08 Test2	98	0	100	131	1,9	0,0	10,1
L09 Test 1	100	0	92	187	5,1	9,1	29,4

Table D.3 (continued)

Lab ID/Test	Recovery %	Males (mean/max) %	Fertility %	Reproduction Number of offspring per test organism	%CV Growth %	%CV Fertility %	% CV Reproduction %
L10 Test 2	86,4	0	97,4	239	0,8	5,7	25,0
L12 Test1	98	2/10	100	131	2,5	6,3	18,1
L12 Test2	88	0	100	119	4,6	6,3	21,9
L01 Test1	88	0	100	186	1,8	0,0	19,2

## Bibliography

- [1] TRAUNSPURGER W., The biology and ecology of lotic nematodes. *Freshw. Biol.* **44**: pp. 29-45, 2000
- [2] FRECKMAN D.W. Nematodes in Soil Ecosystems. In FRECKMAN DW ed. *University of Texas Press*, Austin, TX, USA, 1982
- [3] YEATES G.W., BONGERS T, DE GOEDE R.G.M., FRECKMAN DW, GEORGIEVA SS., Feeding habits in soil nematode families and genera — An outline for soil ecologists. *J. Nematol.* **25**: pp. 315–331, 1993
- [4] MAJDI N., TRAUNSPURGER W., Free-Living Nematodes in the Freshwater Food Web: A Review. *J. Nematol.* **47**: pp. 28–44, 2015
- [5] BONGERS T., FERRIS H., Nematode community structure as a biomonitor in environmental monitoring. *Trends Ecol. Evol.* **14**: pp. 224–228, 1999
- [6] NEHER D.A., Role of nematodes in soil health and their use as indicators. *J. Nematol.* **33**: pp. 161–168, 2001
- [7] HÖSS S., TRAUNSPURGER W., ZULLINI A. Freshwater nematodes in environmental science. In EYUALEM A, TRAUNSPURGER W, ANDRASSY I eds, *Freshw. Nematodes — Ecol. Taxon.* CABI Publishing, Cambridge, MA, USA, pp 144–162, 2006
- [8] HÖSS S., CLAUS E., VON DER OHE P.C., BRINKE M., GÜDE H., HEININGER P., TRAUNSPURGER W., Nematode species at risk — A metric to assess pollution in soft sediments of freshwaters. *Environ. Int.* **37**: pp. 940–949, 2011
- [9] WILSON M., KAKOULI-DUARTE T. *Nematodes as Environmental Indicators.* CABI, Wallingford, UK, 2009
- [10] FÉLIX M.-A., BRAENDLE C., The natural history of *Caenorhabditis elegans*. *Curr. Biol.* **20**:R965–9, 2010
- [11] EYUALEM A, TRAUNSPURGER W, ANDRASSY I. Freshwater Nematodes — Ecology and Taxonomy. In EYUALEM A, TRAUNSPURGER W, ANDRASSY I eds. *CABI Publishing*, Cambridge, MA, USA, 2006
- [12] SUDHAUS W., Vergleichende Untersuchungen zur Phylogenie, Systematik, Ökologie, Biologie und Ethologie der Rhabditidae (Nematoda). *Zoologica.* **43**: pp. 1–229, 1976
- [13] HIRSCHMANN H., Die Nematoden der Wassergrenze mittelfränkischer Gewässer. *Zool. Jahrbücher.* **81**: pp. 313–436, 1952
- [14] ZULLINI A., The ecology of the Lambro river. *Riv. di Idrobiol.* **27**: pp. 39–58, 1988
- [15] RIDDLE D.L., BLUMENTHAL T., MEYER B.J., PRIESS J.R. *C. elegans II.* Cold Spring Harbor Laboratory Press, Cold Spring Harbor, NY, USA, 1997
- [16] KALETTA T., HENGARTNER M.O., Finding functions in novel targets: *C. elegans* as a model organism. *Nat. Rev. Drug Discov.* **5**: pp. 387–398, 2006
- [17] LEUNG M.C.K., WILLIAMS P.L., BENEDETTO A., AU C., HELMCKE K.J., ASCHNER M., MEYER J.N., *Caenorhabditis elegans*: An emerging model in biomedical and environmental toxicology. *Toxicol. Sci.* **106**: pp. 5–28, 2008
- [18] HÖSS S., WILLIAMS P.L. Ecotoxicity testing with nematodes. In WILSON M, KAKOULI-DUARTE T eds, *Nematodes As Environ.* Bioindic. CABI, Wallingford, UK, pp 208–224, 2009
- [19] TRAUNSPURGER W., HAITZER M., HÖSS S., BEIER S., AHLF W., STEINBERG C.E.W., Ecotoxicological assessment of aquatic sediments with *Caenorhabditis elegans* (Nematoda) — A method for testing in liquid medium and whole sediment samples. *Environ. Toxicol. Chem.* **16**: pp. 245–250, 1997

- [20] Höss S., JÄNSCH S., JUNKER T., MOSER T., RÖMBKE J., Assessing the toxicity of contaminated soils using the nematode *Caenorhabditis elegans* as test organism. *Ecotoxicol. Environ. Saf.* **72**: pp. 1811–1818, 2009
- [21] Höss S., AHLF W., FAHNENSTICH C., GILBERG D., HOLLERT H., MELBYE K., MELLER M., HAMMERS-WIRTZ M., HEININGER P., NEUMANN-HENSEL H., OTTERMANN R., RATTE H.T., SEILER T.B., SPIRA D., WEBER J., FEILER U., Variability of freshwater sediment contact tests in sediments with low-level anthropogenic contamination — Determination of toxicity thresholds. *Environ. Pollut.* **158**: pp. 2999–3010, 2010
- [22] HUGUIER P., MANIER N., MÉLINE C., BAUDA P., PANDARD P., Improvement of the *Caenorhabditis elegans* growth and reproduction test to assess the ecotoxicity of soils and complex matrices. *Environ. Toxicol. Chem.* **32**: pp. 2100–2108, 2013
- [23] Rudel D., Douglas C.D., Huffnagle I.M., Besser J.M., Ingersoll C.G., Assaying environmental nickel toxicity using model nematodes. *PLoS One.* **8**:e77079, 2013
- [24] Höss S., AHLF W., BERGTOLD M., BLUEBAUM-GRONAU E., BRINKE M., DONNEVERT G., MENZEL R., MÖHLENKAMP C., RATTE H.T., TRAUNSPURGER W., VON DANWITZ B., PLUTA H.-J., Interlaboratory comparison of a standardized toxicity test using the nematode *Caenorhabditis elegans* (ISO 10872). *Environ. Toxicol. Chem.* **31**: pp. 1525–1535, 2012
- [25] ISO 11465:1993, *Soil quality — Determination of dry matter and water content on a mass basis — Gravimetric method*
- [26] ISO 10390:2005, *Soil quality — Determination of pH*
- [27] ISO 11265:1994, *Soil quality — Determination of the specific electrical conductivity*
- [28] ISO 14688-1:2017, *Geotechnical investigation and testing — Identification and classification of soil — Part 1: Identification and description*
- [29] ISO 10523:2008, *Water quality — Determination of pH*
- [30] ISO 7888:1985, *Water quality — Determination of electrical conductivity*
- [31] Altun, Z.F. and Hall, D.H. 2009. Introduction. In *WormAtlas*. [doi:10.3908/wormatlas.1.1](https://doi.org/10.3908/wormatlas.1.1)

